



Mini element automat MTC 100

Antall poler: 2

Antall moduler: 1

Merkestrøm: 16A

Karakteristikk: C

Merkespenning: 230-240V

Elnr: 1606408

Standard;	EN 60898, EN 60947-2	Frekvens (Hz)	50/60 Hz
Bryte kapasitet EN 60898 230V (Icn)	10000A	Bryte kapasitet EN 60898 230V (Ics)	0,75 x Icn
Bryte kapasitet EN 60947-2 230V (Icu)	10 kA	Bryte kapasitet EN 60947-2 (Ics)	75% Icu
Isolasjonsspenning	500 V	Nominell impulsstøtspenning	4 kV
Minimum drift spenning	12VAC/DC	Maks driftsspenning	253VAC/110VDC
Antall inn/utkoblinger elektrisk	10 000	Antall inn/utkoblinger mekanisk	20 000
Tverrsnitt enleder kabel	$\leq 1 \times 16 - \leq 1 \times 10 + 1 \times 6 \text{ mm}^2$	Tverrsnitt fleksibel kabel	$\leq 1 \times 10 - \leq 2 \times 6 \text{ mm}^2$
Tiltrekningsmoment	1,2Nm	Driftstemperatur	-25 til +60° C
Lagringstemperatur	-40 til + 70° C	Electrocod	1411

## Dimensjon

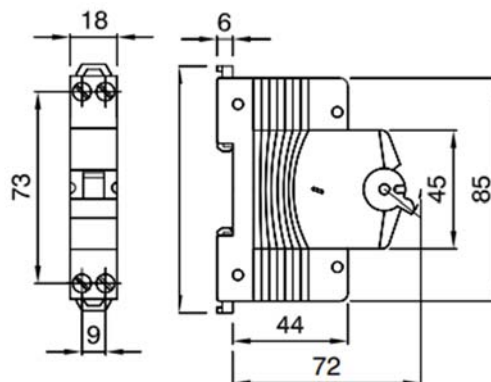

## Standarder/godkjenninger

